

INSTALLATION INSTRUCTIONS

Intermittent Wiper Module - VW – Part Number 13011

Thank you for your purchase of this Intermittent Wiper Module. Adding this module to a factory two-speed wiper switch/motor gives you three additional wiper settings: one swipe every eight seconds, once every five seconds, and once every three seconds. This wiper is designed to work with VW vehicles with two-speed wiper motors. Single speed wiper motors can be utilized, but bare in mind there will be no “fast speed” operation when the module is put into this mode. This module will work with 6V or 12V systems.

Parts Included in this Kit

1-Controller Unit with Harness
6-Heat Shrink tubing

1-Small crimp ring
2-zip ties

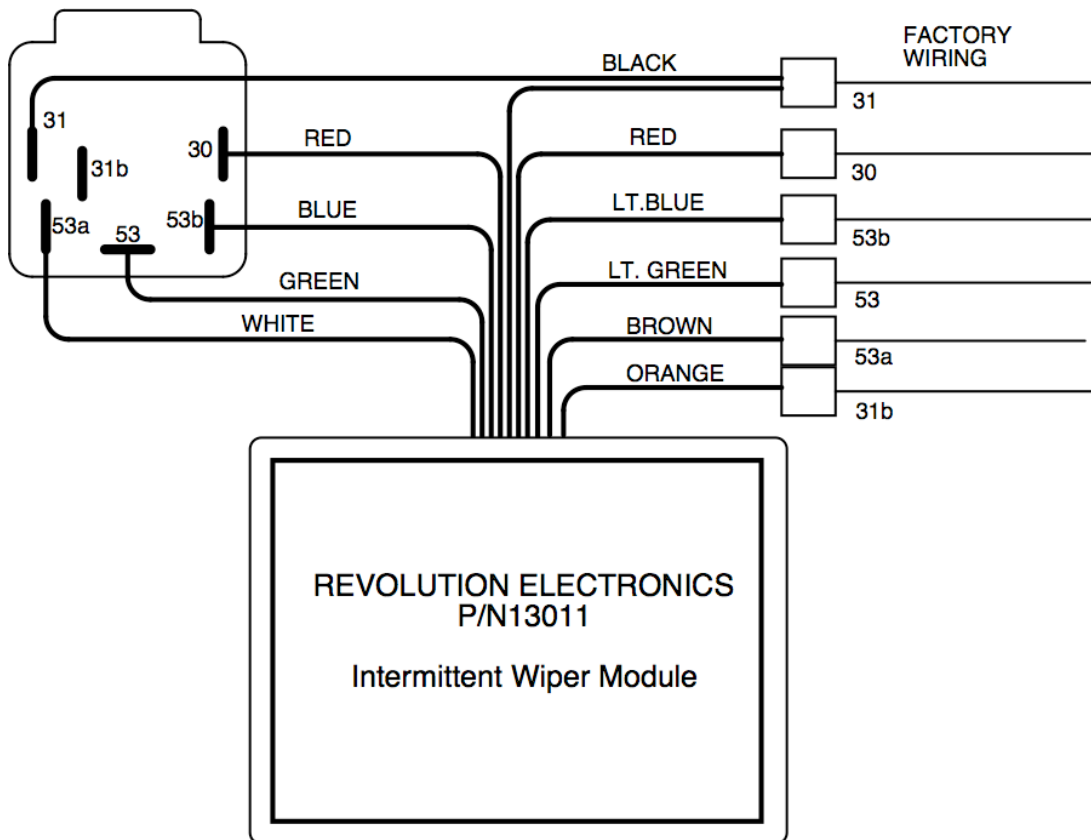

Figure 1

**REVOLUTION
ELECTRONICS**
www.revolutionelectronics.com
Cypress, California 90630

Electrical Connections

Figure 1 summarizes the connections necessary. Installation in a VW is actually pretty straightforward and if done one wire at a time, is not at all difficult.

Black – Ground. Connect to the switch and factory harness.

Red Wires - System power. Connect the Red wire with the male spade connector to the factory harness as shown. The second Red wire from the module (with a female terminal attached) should attach to the factory switch as shown.

Blue Wire – Fast speed position on switch.

Green Wire – Slow speed position on switch.

White Wire – Park position on switch.

Light Blue Wire – Fast speed at the motor.

Light Green Wire – Slow speed at the motor.

Brown Wire – For parking the wipers.

Orange Wire – Causes the motor to stop at the park position.

Mounting the Unit

The Intermittent Wiper Module is intended to mount behind the dash cluster, near the wiper switch, but may be mounted in any location where the electrical connections are easily accessible. Mounting in a weatherproof location is recommended. Use two self-tapping screws, rivets, or zip-ties through the mounting tabs to securely mount the unit.

Operation

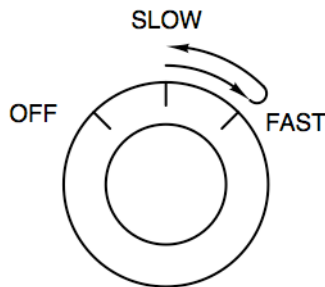

Figure 2: Advancing from one setting to the next

Cycle from: Off--8sec delay--5sec delay--3sec delay--continuous slow--continuous fast

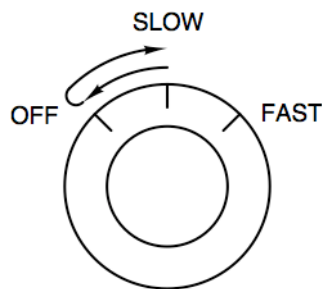

Figure 3: Stepping back through settings

Cycle from: continuous fast--continuous slow--3sec delay--5sec delay--8sec delay--Off

The factory switch has three positions: off, slow, and fast. The Intermittent Wiper Module uses the factory switch to select between several modes of operation. The “off” and “fast” positions retain their functions while the “slow” position becomes a center “neutral point”. Much like paddle shifters can shift a transmission up or down one gear at a time, moving the switch off the center neutral position and back will cause the module to move up or down in its sequence (depending on which side of center you move it). Moving the switch from the center position to the “fast” position and then back to center (within about a half a second) will advance the operation one selection (refer to figure 2). Moving the switch from the center position to the off position and back to the center (again within about a half a second) will step back the operation one selection (refer to figure 3). Within the center position, you can operate the wipers once every 8 seconds, once every 5 seconds, once every 3 seconds, or continuous stock-slow setting.

When you first turn on the wipers by moving the switch from off to center, the wipers will start off operating once every 8 seconds. Quickly moving the switch to the fast position and back to the center will cause the wipers to operate once every 5 seconds. Repeating this operation again will cause them to operate once every 3 seconds. One more time will advance them to the continuous “stock slow” setting. Just as moving the switch from center to fast and back will advance one setting, moving the switch from center to off and back will drop the wipers down one notch. At any time, moving the switch to the fast position and leaving it there will advance the mode directly to the “stock fast” operation. Likewise, moving the switch to the off position and leaving it there will change the mode immediately to off.

**REVOLUTION
ELECTRONICS** 
www.revolutionelectronics.com
Cypress, California 90630

Troubleshooting

There are 10 connections which must be correct for this module to operate properly. Before tearing into the connections at the switch and motor, check these items:

1. Make sure the power (both Red wires) connections are secure.
2. Make sure the ground (Black wire) connection is secure.
3. Make sure the wires to the factory harness are in the correct position (check the wire colors and factory numbering).

Warranty:

All Revolution Electronics products carry a warranty against defects in materials or workmanship for a period of one (1) year from the original retail purchase. Revolution Electronics' liability is strictly limited to the prompt repair or replacement of the defective product. Revolution Electronics shall not be responsible for (a) labor, transportation, or other incidental charges; (b) consequential or other damages incurred by use of any product. Revolution Electronics offers no other warranty beyond this limited warranty. This limited warranty does not apply to products which have been (a) modified or altered in any way; (b) subjected to adverse conditions, misuse, neglect, accident, improper installation or adjustment, contaminants, corrosion, or faulty repair; or (c) used in applications other than those recommended by Revolution Electronics. To initiate a warranty process, the consumer must first contact technical support (tech@revolutionelectronics.com) to receive a return authorization number. The product must be returned to Revolution Electronics complete with a dated receipt and a return authorization number

REVOLUTION
ELECTRONICS
www.revolutionelectronics.com
Cypress, California 90630